

DMC 1,5/ 3-G1-3,5 P35 - PCB header



1053809

<https://www.phoenixcontact.com/pc/products/1053809>

Please be informed that the data shown in this PDF document is generated from our Online Catalog. Please find the complete data in the user documentation. Our General Terms of Use for Downloads are valid.

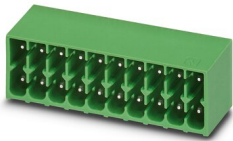

PCB headers, nominal cross section: 1.5 mm², color: green, nominal current: 8 A, rated voltage (III/2): 160 V, contact surface: Tin, type of contact: Pin, number of potentials: 6, number of rows: 2, number of positions: 3, number of connections: 6, product range: DMC 1,5/..-G1, pitch: 3.5 mm, mounting: Wave soldering, pin layout: Linear pinning, solder pin [P]: 3.5 mm, number of solder pins per potential: 1, plug-in system: COMBICON DFMC 1,5, Pin connector pattern alignment: Standard, locking: without, mounting: without, type of packaging: packed in cardboard

Your advantages

- Conductor connection on several levels enables higher contact density
- Small component size for applications where space is at a premium
- Well-known mounting principle allows worldwide use

Commercial Data

Item number	1053809
Packing unit	50 pc
Minimum order quantity	1 pc
Product Key	AABSJA
GTIN	4055626685991
Weight per Piece (including packing)	1.685 g
Weight per Piece (excluding packing)	1.4 g
Customs tariff number	85366930
Country of origin	CN

DMC 1,5/ 3-G1-3,5 P35 - PCB header



1053809

<https://www.phoenixcontact.com/pc/products/1053809>

Technical Data

Product properties

Product line	COMBICON Connectors S
Product type	PCB headers
Product family	DMC 1,5/..-G1
Number of positions	3
Pitch	3.5 mm
Number of connections	6
Number of rows	2
Number of potentials	6
Pin layout	Linear pinning
Solder pins per potential	1

Electrical properties

Nominal current I_N	8 A
Nominal voltage U_N	160 V
Degree of pollution	3
Contact resistance	3 mΩ
Rated voltage (III/3)	160 V
Rated surge voltage (III/3)	2.5 kV
Rated voltage (III/2)	160 V
Rated surge voltage (III/2)	2.5 kV
Rated voltage (II/2)	250 V
Rated surge voltage (II/2)	2.5 kV

Mounting

Mounting type	Wave soldering
Pin layout	Linear pinning

Material specifications

Material data - contact

Note	WEEE/RoHS-compliant, free of whiskers according to IEC 60068-2-82/JEDEC JESD 201
Contact material	Cu alloy
Surface characteristics	Tin-plated
Metal surface contact area (top layer)	Tin (4 - 8 μm Sn)
Metal surface contact area (middle layer)	Nickel (1.5 - 4 μm Ni)
Metal surface soldering area (top layer)	Tin (4 - 8 μm Sn)
Metal surface soldering area (middle layer)	Nickel (1.5 - 4 μm Ni)

Material data - housing

Color (Housing)	green (6021)
Insulating material	PBT

DMC 1,5/ 3-G1-3,5 P35 - PCB header

1053809

<https://www.phoenixcontact.com/pc/products/1053809>

Insulating material group	IIIa
CTI according to IEC 60112	225
Flammability rating according to UL 94	V0

Material data – actuating element

Color ()	()
-----------	-----

Dimensions

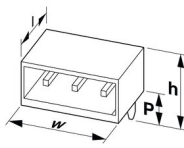
Dimensional drawing	
Pitch	3.5 mm
Width [w]	11.3 mm
Height [h]	14.3 mm
Length [l]	11.6 mm
Installed height	10.8 mm
Solder pin length [P]	3.5 mm

PCB design

Pin spacing	2.50 mm
-------------	---------

Mechanical tests

Test for conductor damage and slackening

Specification	IEC 60999-1:1999-11
Result	Test passed

Repeated connection and disconnection

Specification	IEC 60999-1:1999-11
Result	Test passed

Pull-out test

Specification	IEC 60999-1:1999-11
Conductor cross section/conductor type/tractive force setpoint/actual value	0.2 mm ² / solid / > 10 N
	0.2 mm ² / flexible / > 10 N
	1.5 mm ² / solid / > 40 N
	1.5 mm ² / flexible / > 40 N

Insertion and withdrawal forces

Result	Test passed
No. of cycles	25
Insertion strength per pos. approx.	3 N
Withdraw strength per pos. approx.	2 N

Contact holder in insert

DMC 1,5/ 3-G1-3,5 P35 - PCB header



1053809

<https://www.phoenixcontact.com/pc/products/1053809>

Specification	IEC 60512-15-1:2008-05
Contact holder in insert Requirements >20 N	Test passed

Resistance of inscriptions

Specification	IEC 60068-2-70:1995-12
Result	Test passed

Polarization and coding

Specification	IEC 60512-13-5:2006-02
Result	Test passed

Visual inspection

Specification	IEC 60512-1-1:2002-02
Result	Test passed

Dimension check

Specification	IEC 60512-1-2:2002-02
Result	Test passed

Electrical tests

Thermal test | Test group C

Specification	IEC 60512-5-1:2002-02
Tested number of positions	20

Temperature cycles

Specification	IEC 60999-1:1999-11
Result	Test passed

Air clearances and creepage distances |

Specification	IEC 60664-1:2007-04
Insulating material group	IIIa
Comparative tracking index (IEC 60112)	CTI 225
Rated insulation voltage (III/3)	160 V
Rated surge voltage (III/3)	2.5 kV
minimum clearance value - non-homogenous field (III/3)	1.5 mm
minimum creepage distance (III/3)	2.5 mm
Rated insulation voltage (III/2)	160 V
Rated surge voltage (III/2)	2.5 kV
minimum clearance value - non-homogenous field (III/2)	1.5 mm
minimum creepage distance (III/2)	1.6 mm
Rated insulation voltage (II/2)	250 V
Rated surge voltage (II/2)	2.5 kV
minimum clearance value - non-homogenous field (II/2)	1.5 mm
minimum creepage distance (II/2)	2.5 mm

Environmental and real-life conditions

DMC 1,5/ 3-G1-3,5 P35 - PCB header



1053809

<https://www.phoenixcontact.com/pc/products/1053809>

Vibration test

Specification	IEC 60068-2-6:2007-12
Frequency	10 - 150 - 10 Hz
Sweep speed	1 octave/min
Amplitude	0.35 mm (10 Hz ... 60.1 Hz)
Sweep speed	5g (60.1 Hz ... 150 Hz)
Test duration per axis	2.5 h

Durability test

Specification	IEC 60512-9-1:2010-03
Impulse withstand voltage at sea level	2.95 kV
Contact resistance R ₁	3 mΩ
Contact resistance R ₂	3.5 mΩ
Insertion/withdrawal cycles	25

Climatic test

Specification	ISO 6988:1985-02
Corrosive stress	0.2 dm ³ SO ₂ on 300 dm ³ /40 °C/1 cycle
Thermal stress	105 °C/168 h
Power-frequency withstand voltage	1.39 kV

Ambient conditions

Ambient temperature (operation)	-40 °C ... 100 °C (dependent on the derating curve)
Ambient temperature (storage/transport)	-40 °C ... 70 °C
Relative humidity (storage/transport)	30 % ... 70 %
Ambient temperature (assembly)	-5 °C ... 100 °C

Packaging specifications

Type of packaging	packed in cardboard
-------------------	---------------------

Drawings

Diagram

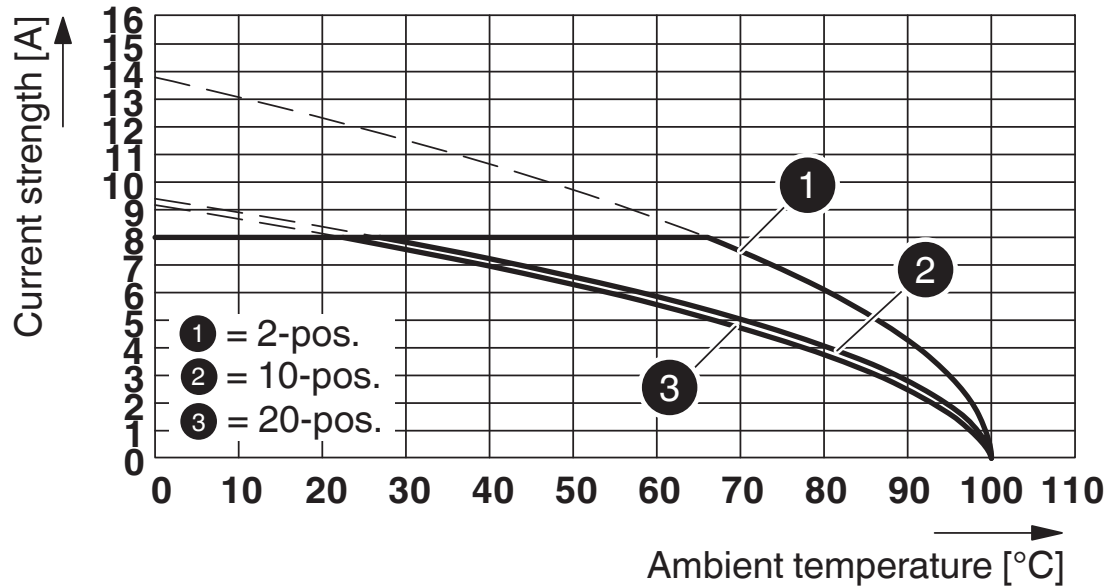

Type: DFMC 1.5/...-ST-3.5 with DMC 1.5/...-G1-3.5 P35

Schematic diagram

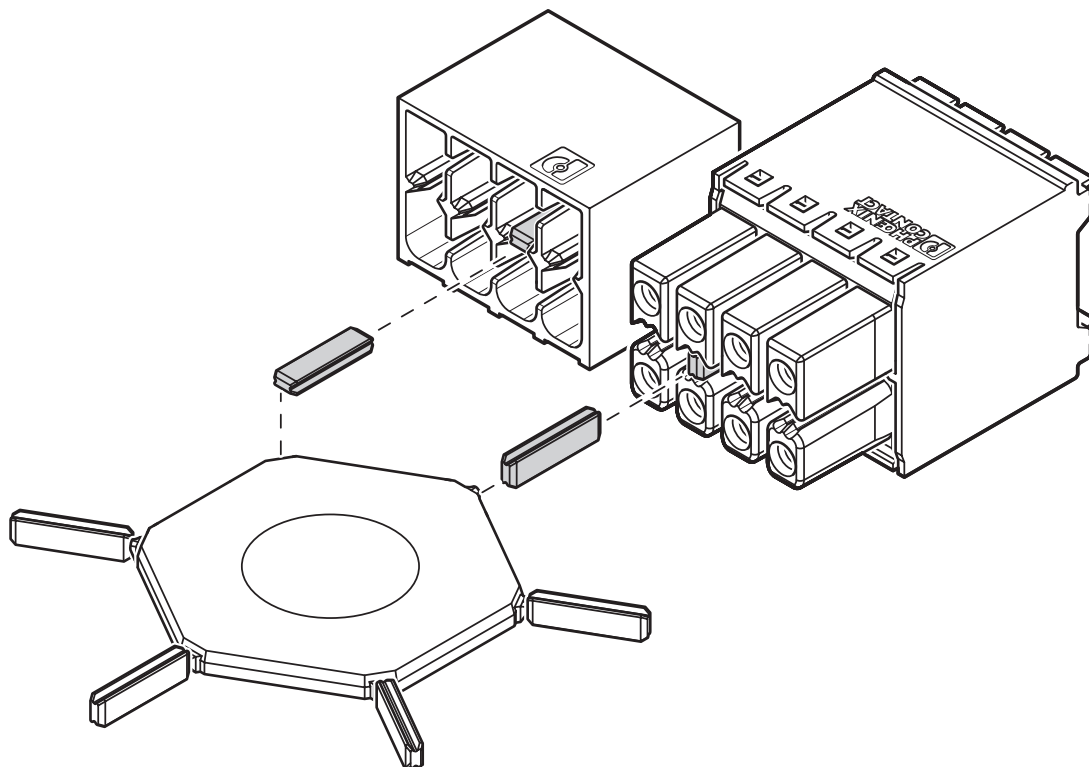

Use of the CP-DMC... coding profile

DMC 1,5/ 3-G1-3,5 P35 - PCB header



1053809

<https://www.phoenixcontact.com/pc/products/1053809>

Approvals



EAC

Approval ID: B.01687



cULus Recognized

Approval ID: E60425-20110128

	Nominal Voltage U_N	Nominal Current I_N	Cross Section AWG	Cross Section mm^2
	150 V	8 A	-	-
	300 V	8 A	-	-

DMC 1,5/ 3-G1-3,5 P35 - PCB header



1053809

<https://www.phoenixcontact.com/pc/products/1053809>

Classifications

ECLASS

ECLASS-11.0	27460201
ECLASS-12.0	27460201
ECLASS-13.0	27460201

ETIM

ETIM 8.0	EC002637
----------	----------

UNSPSC

UNSPSC 21.0	39121400
-------------	----------

DMC 1,5/ 3-G1-3,5 P35 - PCB header



1053809

<https://www.phoenixcontact.com/pc/products/1053809>

Environmental Product Compliance

China RoHS	Environmentally friendly use period: unlimited = EFUP-e
	No hazardous substances above threshold values

DMC 1,5/ 3-G1-3,5 P35 - PCB header

1053809

<https://www.phoenixcontact.com/pc/products/1053809>



Accessories

CP-DMC 1,5 NAT - Coding profile

1790647

<https://www.phoenixcontact.com/pc/products/1790647>

Coding profile, for insertion between the coding ribs of the connector and the header following the reflow soldering process, insulating material, color: natural



DFMC 1,5/ 3-ST-3,5 - PCB connector

1790111

<https://www.phoenixcontact.com/pc/products/1790111>

Plug, nominal current: 8 A, rated voltage (III/2): 160 V, number of positions: 3 with 6 contacts, pitch: 3.5 mm, connection method: spring-cage connection, color: green, contact surface: tin



Phoenix Contact 2023 © - all rights reserved

<https://www.phoenixcontact.com>

PHOENIX CONTACT GmbH & Co. KG

Flachsmarktstraße 8

D-32825 Blomberg

+49 (0) 5235-3 00

info@phoenixcontact.com